

ARCADE 3 MOTORISED SHUTTERS
OVER CENTRE INSTALLATION - SECTION & DETAILS - REFER TO 6AA-3

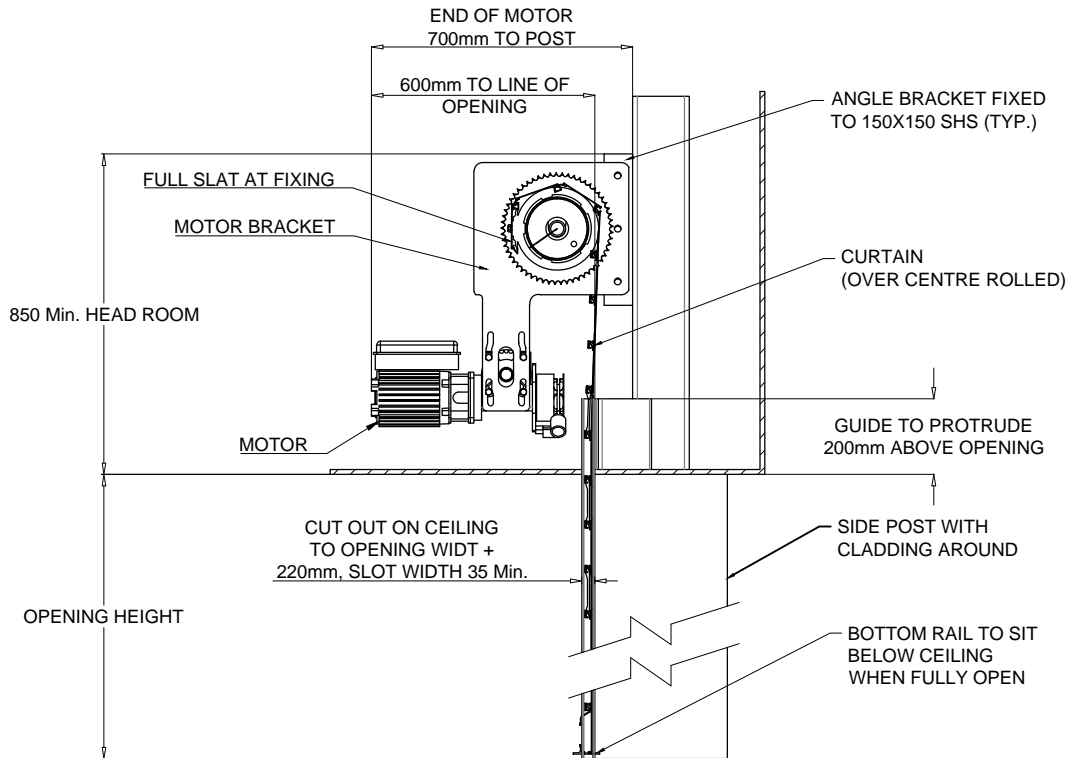

SECTION C-C

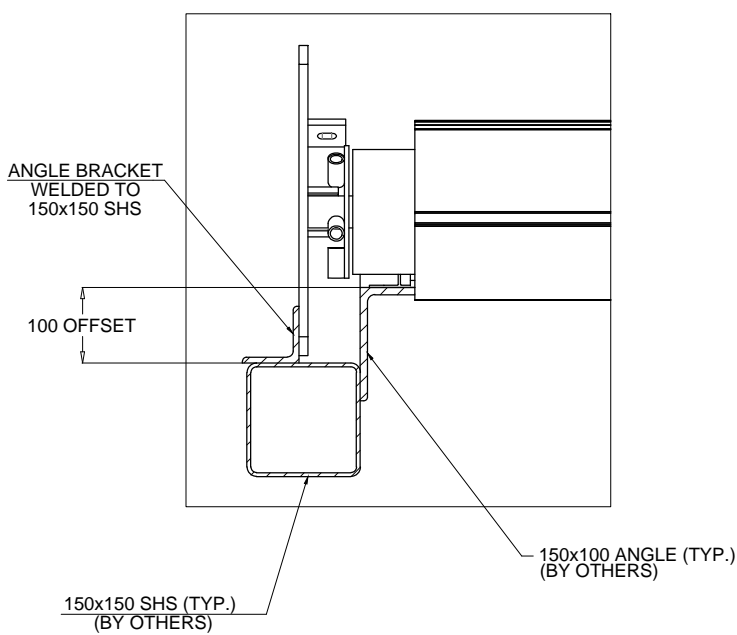

DETAIL D

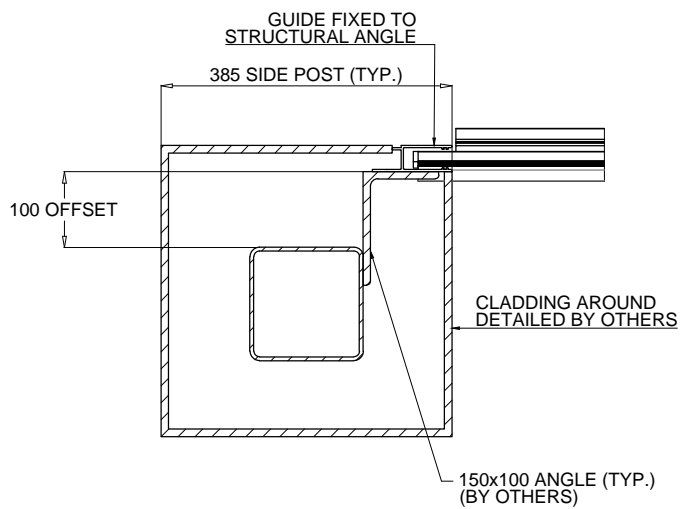

DETAIL E